

55" ANTONIO CAST IRON ROLL TOP TUB

Cat. No.
CTRH54



L: 55-1/2"
W: 30"
H: 25" (from floor to top of tub)
16-1/2" (from bottom of tub to top of tub)

Features:

- ▶ Inside finish is white enamel
- ▶ Tub exterior is white (epoxy)
- ▶ 3-3/8" centers in tub wall
- ▶ Continuous rolled rim
- ▶ Pre-drilled overflow hole
- ▶ Cast Iron ball and claw feet
- ▶ Non-skid strips
- ▶ Feet are attached and leveled before shipment
- ▶ Tub is thoroughly inspected before shipment



Foot Finishes:

BP Polished Brass
PN Polished Nickel
WH White

CP Polished Chrome
SN Brushed Nickel
ORB Oil-rubbed Bronze

Custom Colors Available (inside of tub is always white enamel):
Painted bathtubs are considered "special order" and are not returnable
\$160 Bisque or Black \$250 Designer Color

The following is recommended for CTRH54 tubs with faucet holes:

- Tub wall-mounted faucets or hand-held showers: part# **4022, 4025, 4035**
- Tub wall-mounted faucets for use with risers: part# **4001, 4013, 4023, 4030, 4031**
- Double offset bath supplies: part #**5576**
- Leg tub drain: part #**5599**
- Complete shower unit: part# **4124, 4143**

Gallon Capacity: 36
Shipping Weight: 475 lbs.
Empty Weight: 247 lbs.
Filled Weight: 547 lbs.

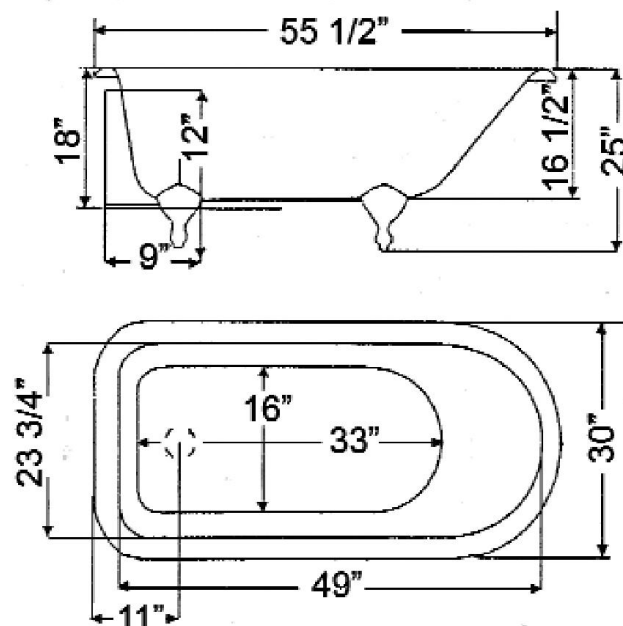

Dimensions of fixture are nominal and may vary within the range of tolerances established by ANSI Standard A112.19.2. Dimensions and specifications subject to change without notice.

TUB WALL-MOUNTED FAUCET WITH HAND SHOWER

Cat. No.

4022



Features:

- ▶ Code gooseneck spout
- ▶ Telephone style handheld shower with cradle and 59" hose
- ▶ Backflow preventor in handshower
- ▶ ¼ turn ceramic disc cartridges
- ▶ 3-3/8" centers for tub wall mount installation
- ▶ Flow rate for spout is 3.68 GPM
- ▶ Flow rate for handshower is 2.5 GPM
- ▶ To be used with double offset bath supplies: part #5576
- ▶ Can be used with freestanding bath supplies Part #4502



W: 9"
D: 9-1/2"
H: 12"

Finishes:

BP	Polished Brass	PN	Polished Nickel
CP	Polished Chrome	ORB	Oil Rubbed Bronze
SN	Brushed Nickel		

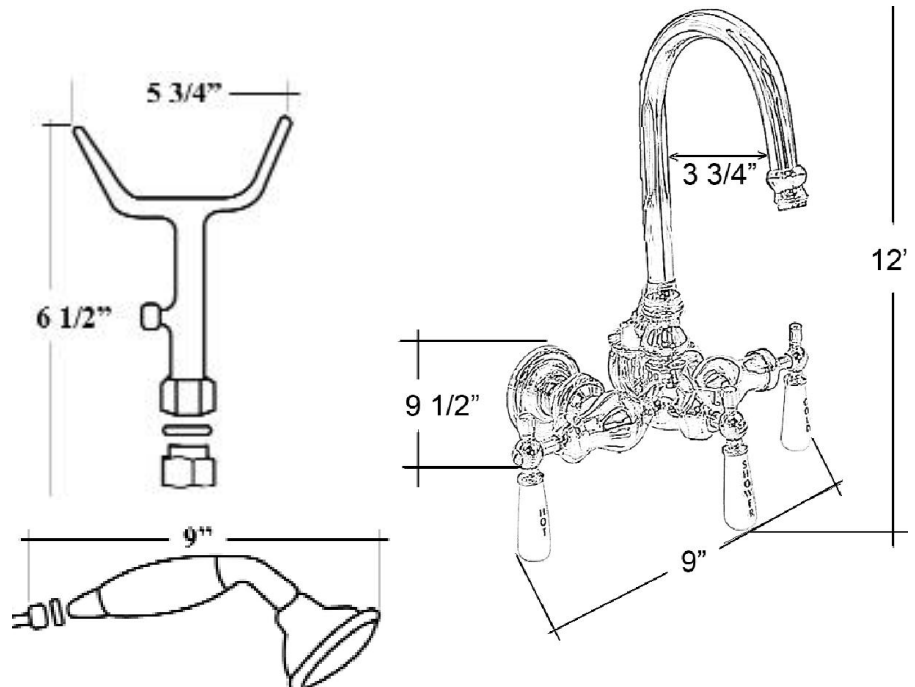
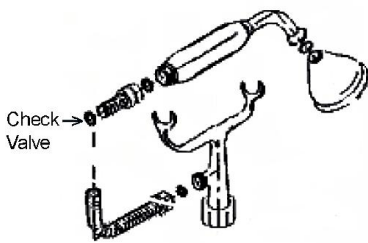

Dimensions are nominal and may vary. Dimensions and specifications subject to change without notice.

DOUBLE OFFSET BATH SUPPLIES

Cat.No.
5576



H: 24"

OD: 1/2"

Features:

- ▶ For use with faucets mounted to the tub wall
- ▶ No Stops
- ▶ 1/2" Compression inlet
- ▶ 3/4" Compression outlet
- ▶ 0.500" Outer diameter
- ▶ 0.440" Inner diameter
- ▶ 0.030" Thickness of the wall
- ▶ Available in 5 finishes

Finishes:

CP	Polished Chrome	PN	Polished Nickel
PB	Polished Brass	BN	Brushed Nickel
ORB	Oil Rubbed Bronze		

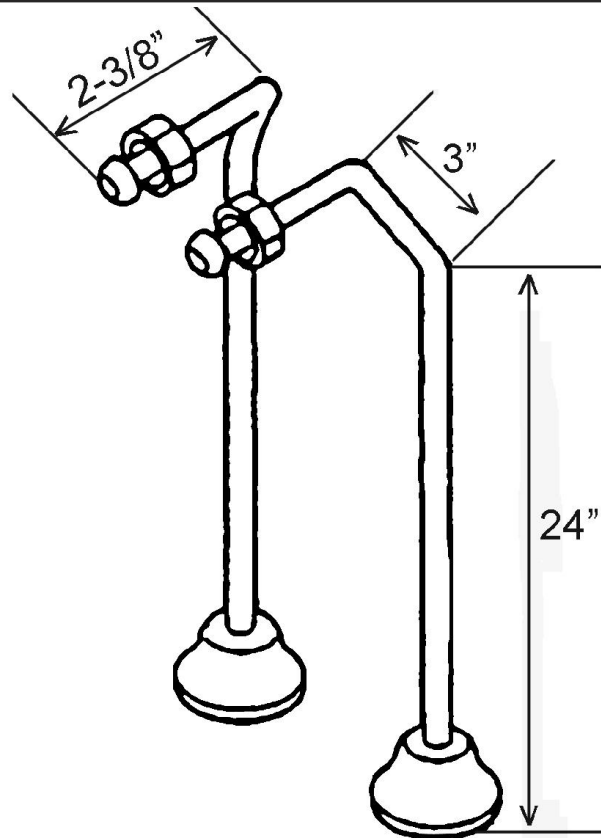

Use on concrete floors requires special installation. We recommend using a plumbing professional.

Dimensions and specifications subject to change without notice.

LEG TUB DRAIN

Cat. No.
5599



Escutcheon Height: 1-1/4"

Features:

- ▶ Twist-and-lift stopper
- ▶ Includes deep escutcheon
- ▶ Height adjustable 15"-18"
- ▶ Depth adjustable 12"-14"
- ▶ Includes deep escutcheon
- ▶ Available in 5 Finishes

Finishes:

- CP Polished Chrome
- BP Polished Brass
- SN Brushed Nickel
- PN Polished Nickel
- ORB Oil Rubbed Bronze

#5599 Leg Tub Drain

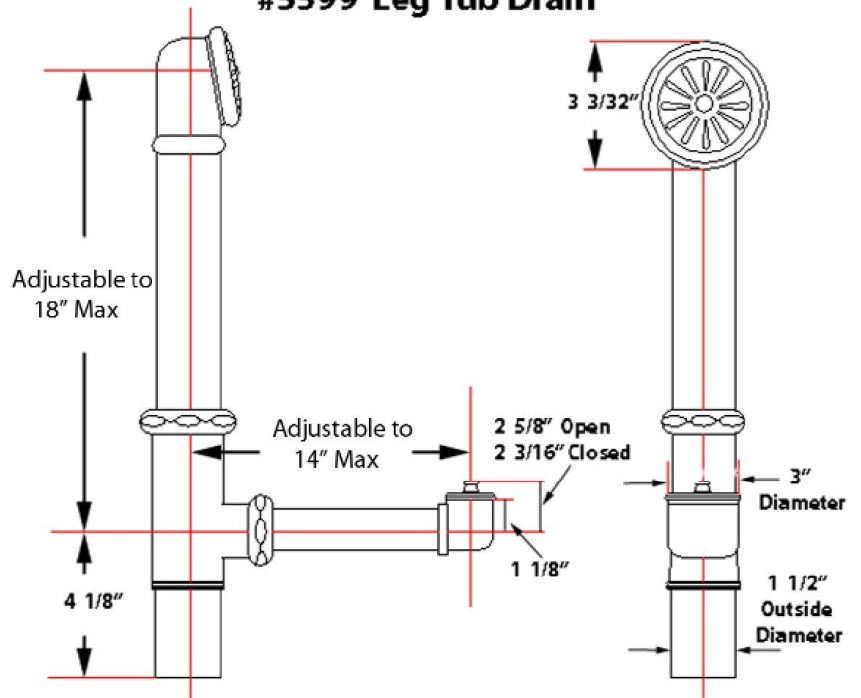

Dimensions and specifications subject to change without notice.